

Ultrasep Superplus UFS-SP/ UFS-SP N

Oil/water separator
for air compressor condensate

Function

A pressure relief chamber separates condensate and expanding air. The condensate then passes a sedimentation compartment – easy to remove and therefore easy to clean.

The next step is the coalescing filter with its additional oil separation effect. Free floating oil is siphoned off into an oil can. In the activated carbon adsorber the water is purified from the last oil droplets. Pure water leaves the unit ready to be drained according to the rules of law.



Safety

The activated carbon is protected by a preadsorber.

A bright yellow floater warns about the beginning of a blockade of the carbon by oil sludge.

The water quality can be checked visibly with a simple turbidity comparison.

The incorporated oil canister can only be changed if the oil flow is interrupted.

Application:

UFS-SP are oil/water separators for the purification of air compressor condensate to legal discharge limits.

Construction

The range of UFS-SP/ UFS-SP N are in total 7 sizes: 5 single units of 2 or 4 separated UFS.

Ultrasep Superplus UFS-SP/ UFS-SP N

Features:	Benefits:
Coalescing filter	Improves oil separation for longer compliance with legal discharge limits.
Sizing	Long residence time ensures excellent gravity separation. Extreme generous filling with activated carbon ensures long service intervals.
Service label on the lid	This service guideline for checking filtrate quality and carbon change procedure can't get lost.
Modular design for UFS-SP 120N and 240N	Quick availability exstock with standard units

UFS-SP	Nom. compressor performance
	m ³ /h
5	120
10N	250
15N	450
30N	900
60N	1800
120N	3600
240N	7200

Materials:	
Body and lid	PE-LLD, recycleble
Filter/ Demister	PUR-foam
Adsorber	PP Activated carbon

Temperature range:	
without heater	+1°C to +60°C
with heater	-25°C to +60°C

Options:	
Heater	230 V/ 50 Hz or 110 V/ 60 Hz

Max. compressor performance for moderate climate (m ³ /min.)		
UFS-SP	Screw compressor	
	Mineral oil	Synthetic oil
5	2	2
10N	4	4
15N	4-8	3-6
30N	8-16	6-12
60N	16-32	12-24
120N	32-64	24-48
240N	64-128	48-96

Max. compressor performance for tropical climate (m ³ /min.)		
UFS-SP	Screw compressor	
	Mineral oil	Synthetic oil
5	0.5-1	0,5-1
10N	1.5-3	1-2
15N	2.5-5	2.5-5
30N	5.5-11	4-8
60N	10.5-21	7-14
120N	21.5-43	16-32
240N	42.5-85	32-64

Example:

Screw compressors, mineral oil, total 20 m³/min.:
select UFS-SP 60N

Ultrasep Superplus UFS-SP/ UFS-SP N

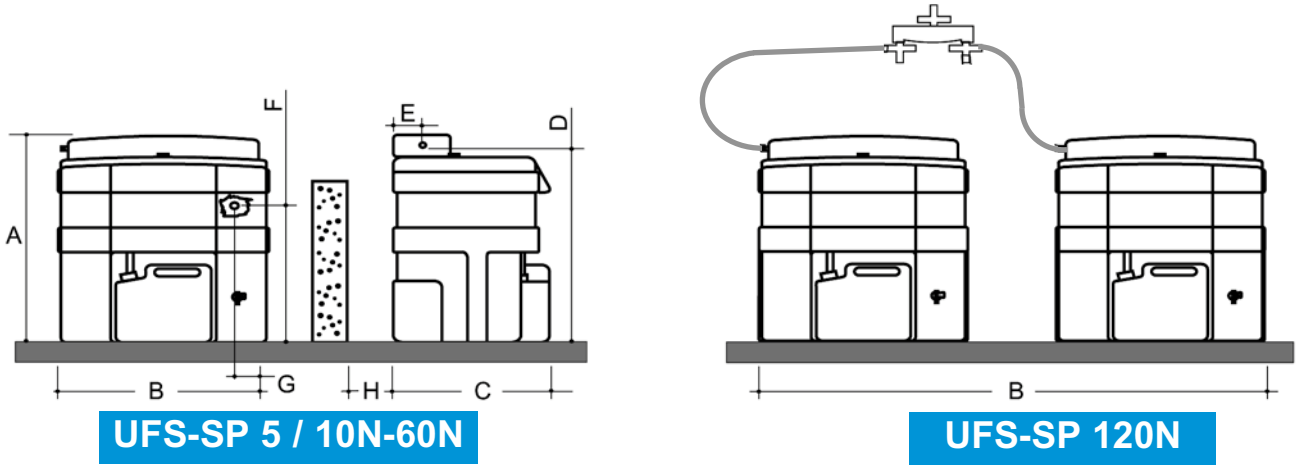

UFS-SP 5 / 10N-60N

UFS-SP 120N

Condensate entry:

UFS-SP 5:

1/2"

UFS-SP 10N - 60N:

1x1" / 3x 1/2"

Condensate exit:

UFS-SP 5:

1/2"

UFS-SP 10N - 60N:

1"

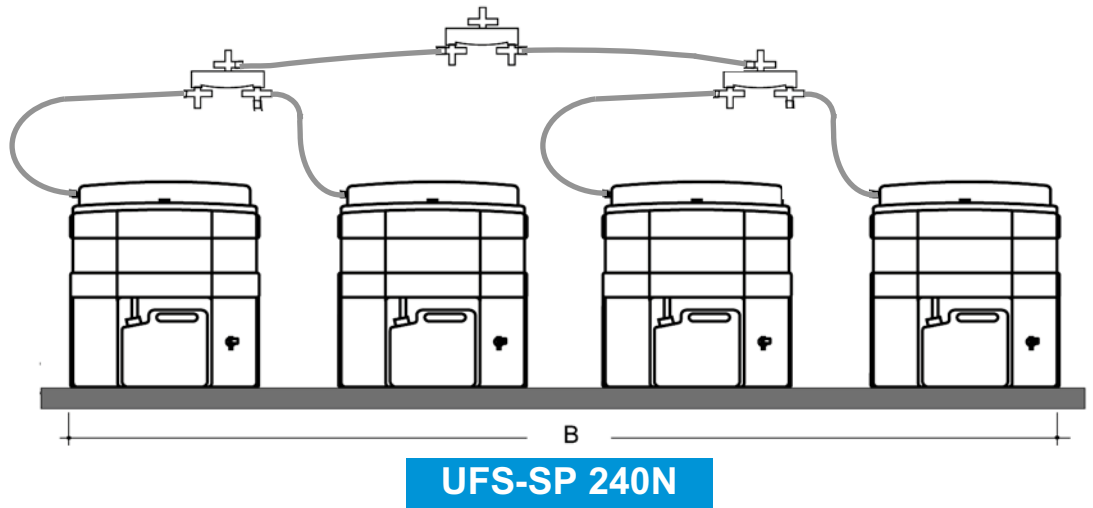

UFS-SP 240N

Type	Dimensions								Volumes				Freight weight
	A	B	C	D	E	F	G	H	Vessel	Activated carbon	Pre-adsorber	Oil can	
	mm	mm	mm	mm	mm	mm	mm	mm	Liters	Liters	Liters	Liters	kg
5	555	345	320	505	100	380	145	100	25	3,1	0.9	2.5	8.5
10N	655	445	430	610	60/120	400	250	170	50	8	3.2	5	19.5
15N	735	495	460	670	60/120	465	275	170	75	12	3.8	10	23.5
30N	840	680	510	790	60/120	555	145	170	150	2x11	4.9	20	35.0
60N	985	790	660	960	70/130	690	167	250	300	2x15	5.7	20	67.0
120N	985	1780	660	960	70/130	690	167	250	600	4x15	2x5.7	2x20,0	136.0
240N	985	3760	660	960	70/130	690	167	250	1200	8x15	4x5.7	4x20,0	272.0